

# CHEVALIER®

**FSG-2040ADII/2060ADII**

**2440ADII/2460ADII/2480ADII**

**COLUMN TYPE HIGH PRECISION 3-AXIS AUTOMATIC SURFACE GRINDER**

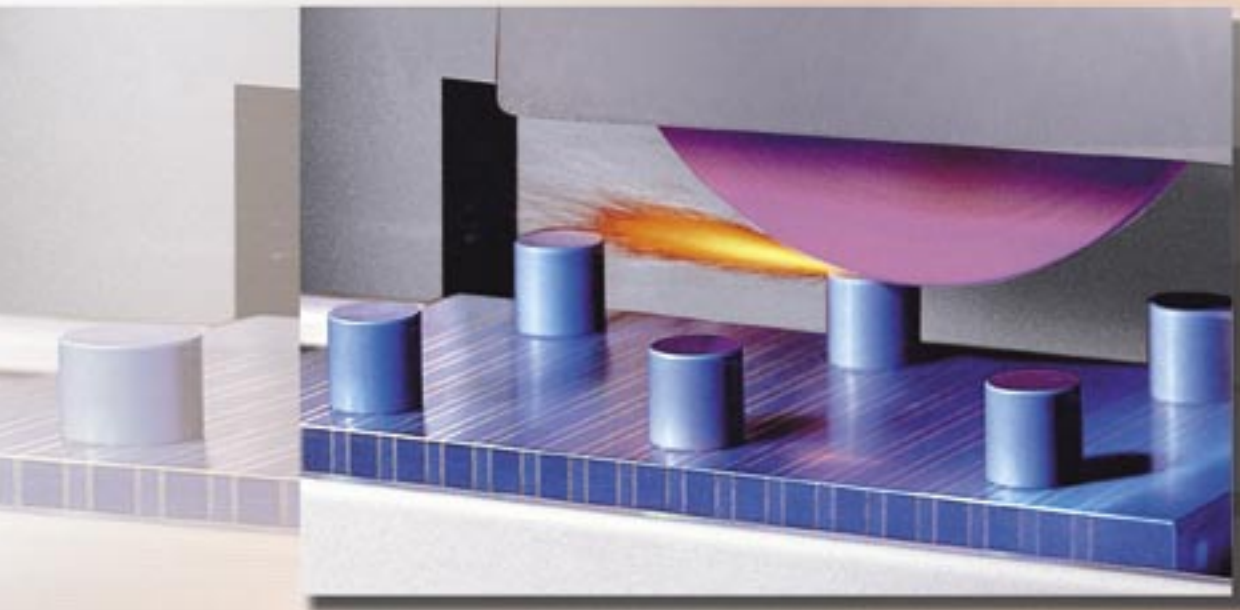

# FSG-20/24A

1

## CONTROL PANEL

## COLUMN TYPE HIGH PRECISION 3-A

1. Control power supply switches and indication lamps.
  2. Provide left end / right end table parking selection.
  3. Pilot lamp shows that fine grinding is performing.
  4. L.E.D. digital screen shows "Y axis position"
  5. "WHEEL LIFT UP TO" switch: Grinding wheel lifts up to start point or reference point after grinding cycle is finished.
  6. Z-axis stroke can be set by using setting key.
  7. Selections steps for wheel dressing interval.
  8. "DRESSING OFFSET" provides the first dressing compensation percentage. The percentage is chosen according to operator's grinding experience. The percentage of dressing compensation will be performed right after dressing is complete.
  9. Separate switch provides crossfeed increment for rough and fine grinding.
- The balance will be compensated at next downfeed increment.



## CONTROL STATION

### 1. Mode Selector



### 2. Total Removal Amount

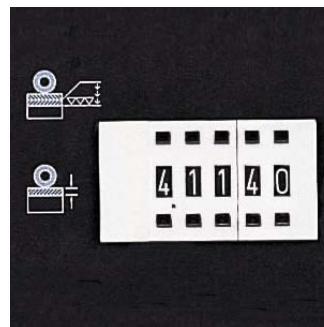

Total removal amount can be set by pushing the "+" or "-" to increase or decrease each digit.

### XIS AUTOMATIC SURFACE GRINDER

#### 3. Y Axis Downfeed Amount Display.

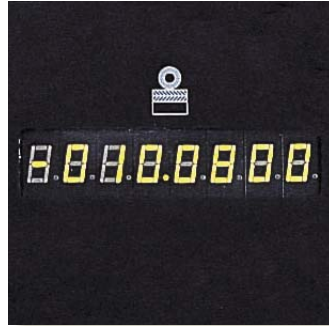

#### 4. Rough Grinding Increment Selector

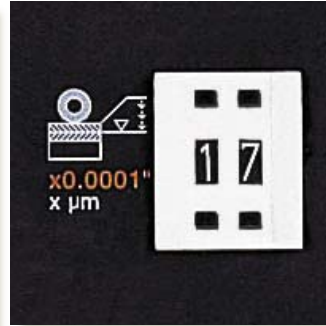

Rough grinding downfeed increment can be selected and the range is 0"~0.0099" (0 μm~99 μm).

#### 5. Fine Grinding Increment Selector

The fine grinding downfeed increment can be selected and the range is 0" ~ 0.0009" (0 μm ~ 20 μm).



#### 6. Fine Grinding Start Point Selector

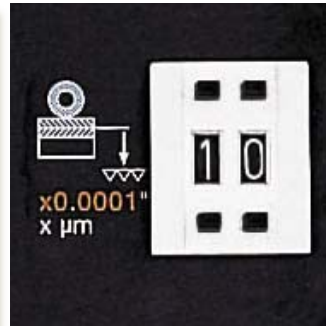

The Start of line grinding can be selected and the range is 0"~0.0020" (0 μ~40 μm)

#### 7. Crossfeed Reversal Point Setting

To set crossfeed reversal points, move saddle to desired "in" reversal position & press stroke set and repeat afore mentioned steps to set desired "out" reversal position.

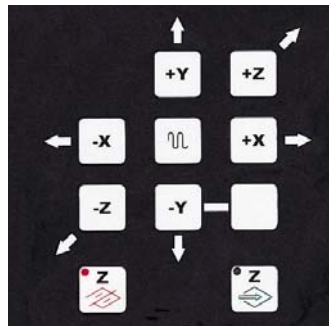

#### 8. Crossfeed (Z axis) Increment Selectors

A rough crossfeed increment is set for rough grinding, and fine increment is set for fine grinding. Each setting corresponds with rough and fine crossfeed increments.



#### 9. Dress setting

The operator can set the dress amount from 0.0002"~0.0008" (0.005mm~0.02mm), dressing passes across the wheel from 1 to 4, and dress frequency during rough and fine grinding. The wheelhead position is automatically compensated during AUTO dressing (optional).

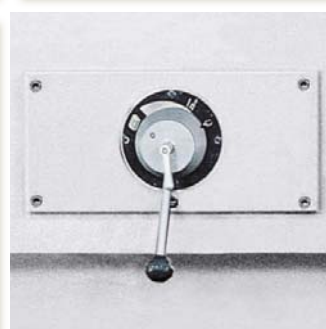
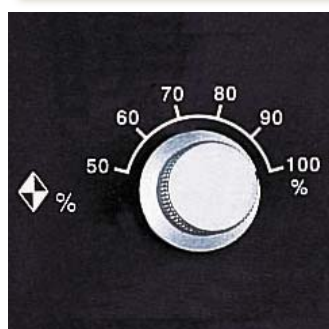
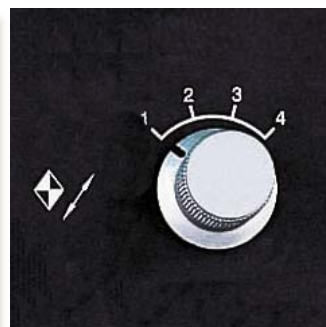

#### 10. Table (X axis) Speed Adjustment

Table speed can be adjusted by table speed control lever from 16~82FPM (5~25m/min).

FSG-2040ADII • 2060ADII

FSG-2440ADII • 2460ADII • 2480ADII

COLUMN TYPE HIGH PRECISION 3-AXIS AUTOMATIC SURFACE GRINDER

### Programmable Controlled Grinding Machine

The machine with micro-processor is programmed to perform rough grinding, fine grinding sparkout passes, automatic overwheel dressing and compensation for wheel dress amount. After grinding, table can be set to park either left end or right end. Spindle can be set to stop running or keep running and wheelhead can also be set to lift up to start point or reference point after grinding cycle finished. The machine is suitable for mass production.

### Precision Spindle And Rigid Elevating Guideways

The rigid wheelhead houses a large diameter cartridge type spindle supported by 6 super precision class 7 (P4) permanently lubricated angular contact ball bearings (4 pcs for 20 series). The precisely balanced spindle motors are air cooled to ensure optimum surface finishes and maintain superior accuracies.

### Automatic Wheel Dressing With Compensation (Optional)

The machine efficiency is maximized by automatic dressing with automatic dressing compensation during rough and/or fine grinding and at the end of rough grinding. This allows machine to run unattended, and reduces machining costs.

### Completely Supported Guideways

Extended base guideways for crossfeed and longitudinal travel enhance machine rigidity & stability and upgrade machine accuracy & longevity. The permissible loads can be completely supported and table overhang is eliminated.

### Grinding flow chart

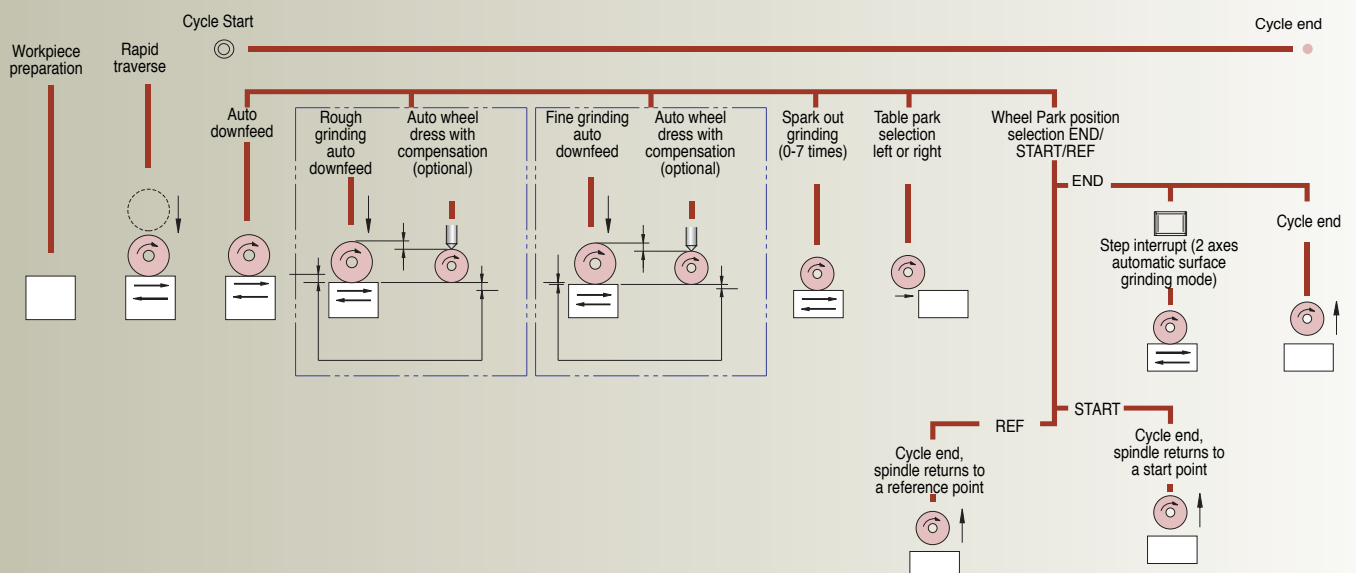

### Rigid Construction

All essential casting are made of high grade dense cast iron which has been stress relieved and ribbed with honeycomb ribs to enhance rigidity and increase stability thereby increasing cutting capability.

### Crossfeed Stroke Setting

The crossfeed travel is set with push buttons on control panel. This new break through in design is more efficient and user friendly.

### AC Servo Vertical Drive

The wheelhead, travelling on hardened and ground square ways coated with Turcite-B system is cooperated with hardened and ground leadscrew (20 series) and precision ballscrew (24 series), and an AC servo motor to provide high torque, speed and accurate positioning with a minimum increment of 0.0001" (0.001mm). A manual pulse generator (MPG) is standard for easy operation.

### Crossfeed Speed Control

Column continuous movement speed is controlled by a frequency converter for obtaining better grinding surface finish and better dressing result from table. Na feumsan henit elis duis eum numsan

# 24ADII Series

## 3-AXIS AUTOMATIC SURFACE GRINDER



**FSG-2060ADII**

Note: Machine shown with optional accessories

### GRINDING MODE

1. Surface grinding

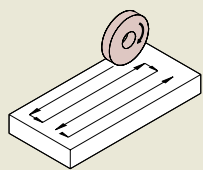

2. Plunge grinding

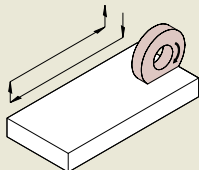

3. Crisscross grinding

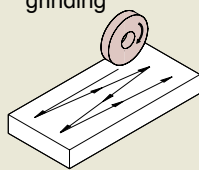

4. CBN



### Column

The column is made of high grade dense iron which has been stress relieved and ribbed with honeycomb type ribs to enhance rigidity and increase stability thereby increasing grinding performance.

### MACHINE CONSTRUCTION(20 series)

#### Spindle

Spindle is supported by 4 pieces (6 pieces for 24 series) of class 7 (P4) super precision angular contact ball bearings which have been accurately measured, selected and preloaded, and then assembled in a temperature controlled clean room. Spindle is permanently lubricated and requires no maintenance. Large diameter spindle is precisely balanced to ensure accuracy.

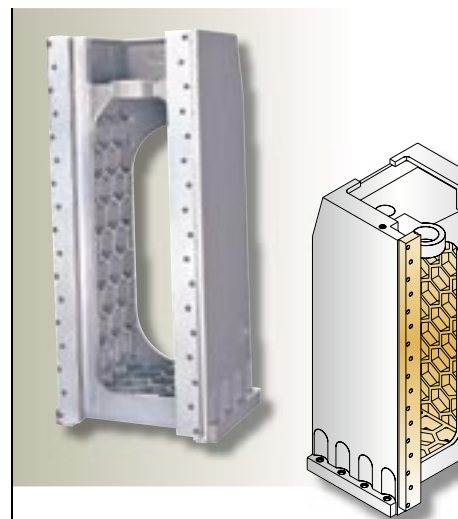
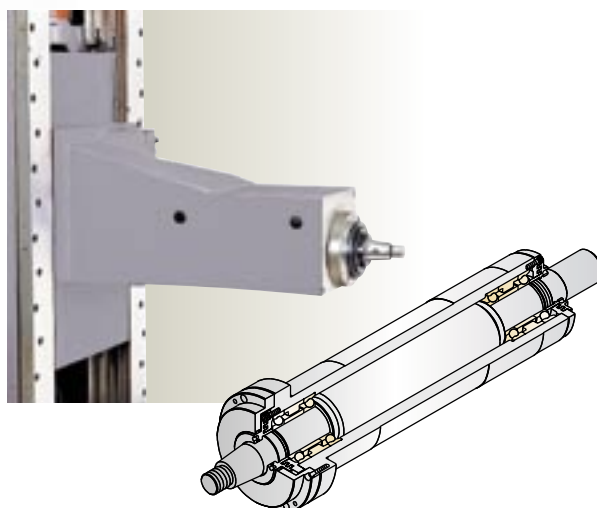

# FSG-20/24AD

## COLUMN TYPE HIGH PRECISION 3-AXIS AUT

### Longitudinal Stroke Adjustment Device

Table reversal is controlled by proximity switches which never make contact. It is simple for operator to adjust table reversal to minimum required stroke, thereby grinding less air and reducing grinding time. Stroke adjustment protection plate is designed to allow table stroke to be adjusted safely.

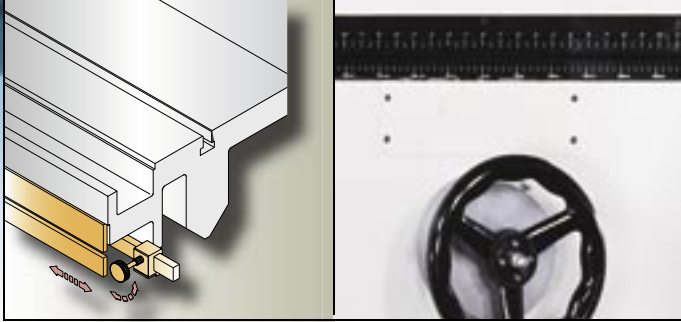

### Longitudinal Slide Way

One "V" and one flat table guideways are laminated with TURCITE-B & precisely hand scraped to ensure high accuracies. Continuous lubrication is provided to assure smooth stick-slip free movement of the table & accurate positioning.

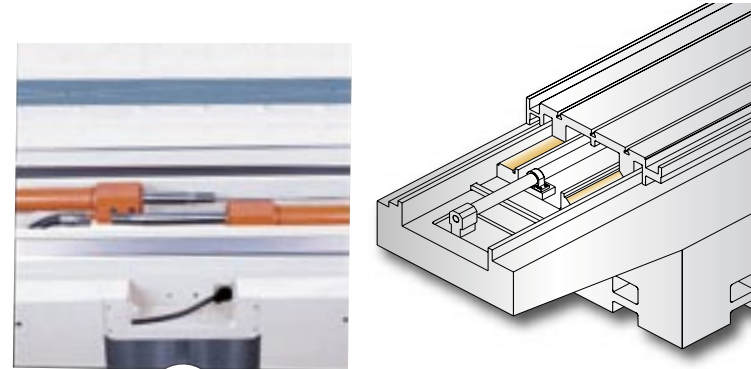

### Crossfeed Guideways

Double "V" guideways are ground and laminated with Turcite-B then precisely hand scraped. Continuous lubrication is provided to ensure smooth & precise crossfeed increments.

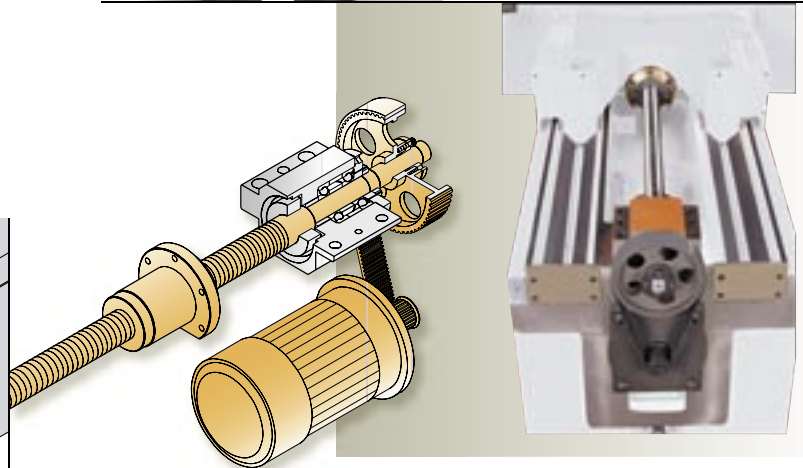
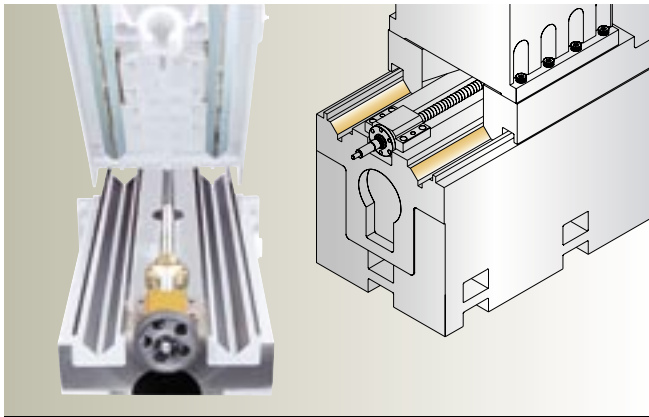

### Crossfeed Transmission Mechanism

Enlarged precision leadscrew with backlash adjustment device is driven by an AC motor. The encoder type stroke setting key allows crossfeed reversal points to be set from operators control panel, thereby working efficiency is increased.

### Elevating Transmission Mechanism

The wheelhead travelling on a preloaded hardened and ground guideway system is driven by a hardened and ground leadscrew and an AC servo motor providing high torque, speed and accurate positioning with minimum increment of 0.0001" (0.001mm). A manual pulse generator (MPG) is standard for easy operation.

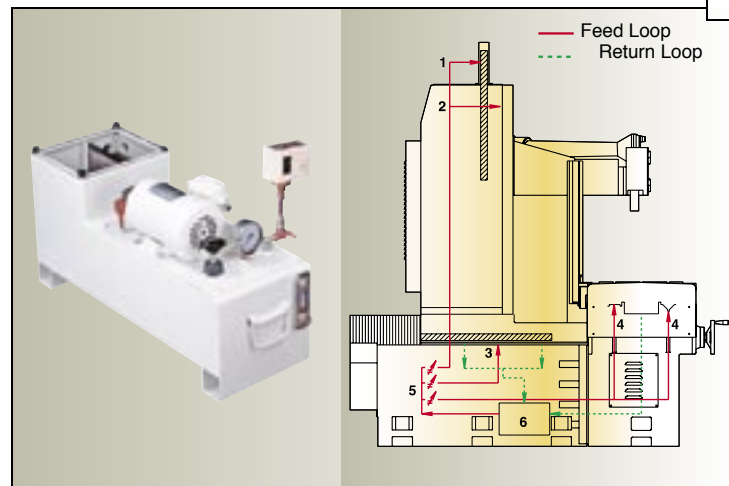
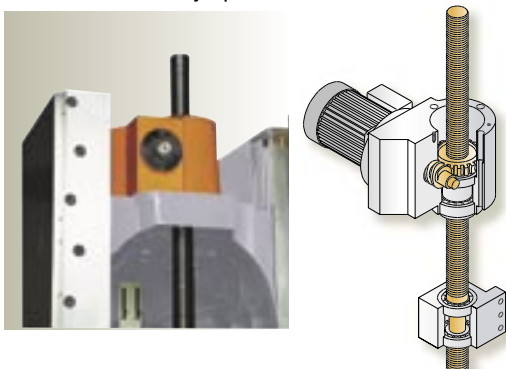

cast  
bbed  
dity  
the



1.  
2.  
3.  
4.  
5.  
6.

# II Series

## OMATIC SURFACE GRINDER

(24 series)

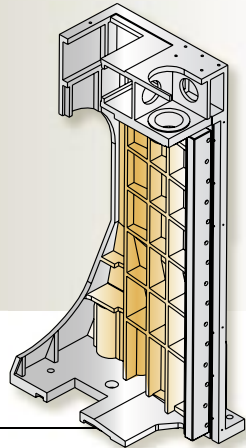

### Column

The column is made of high grade dense cast iron which has been stress relieved. With ribbed and computer-analyzed structure, the stability and rigidity is greatly increased. Spindle travels on hardened and ground square ways, and is driven by precision ballscrew and an AC servo motor for heavy grinding and smooth & accurate movement.

### Crossfeed Slideway

Hardened and ground guideways are laminated with Turcite-B, then precisely hand scrapped. Continuous lubrication is provided to assure smooth stick-slip free movement of the table & accurate positioning.

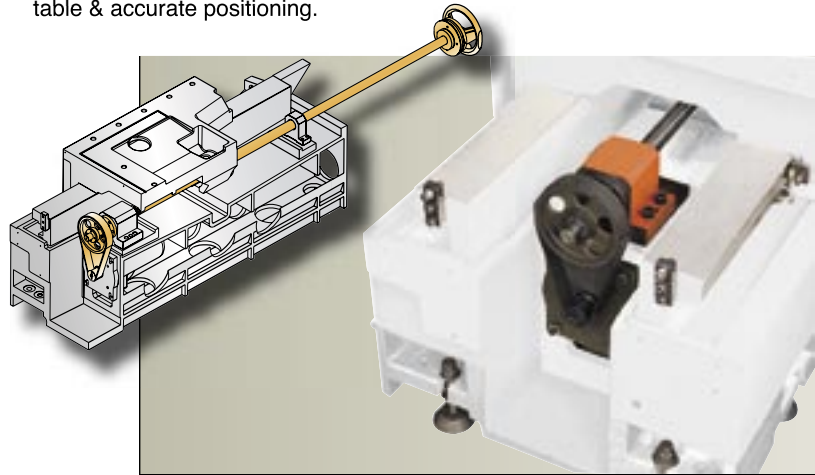

### Longitudinal Slideways

With double "V" guideways, which are laminated with turcite B anti-friction material, for smooth and stable longitudinal movement.

The table is full supported on the well designed front base of machine, Thus, the accuracy is greatly increased.

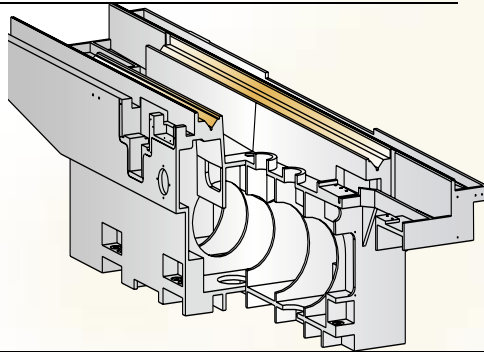

### Spindle Counter Weights Balance System

Hydraulic counter weights balance system is installed to eliminate backlash and wear of elevating screws.

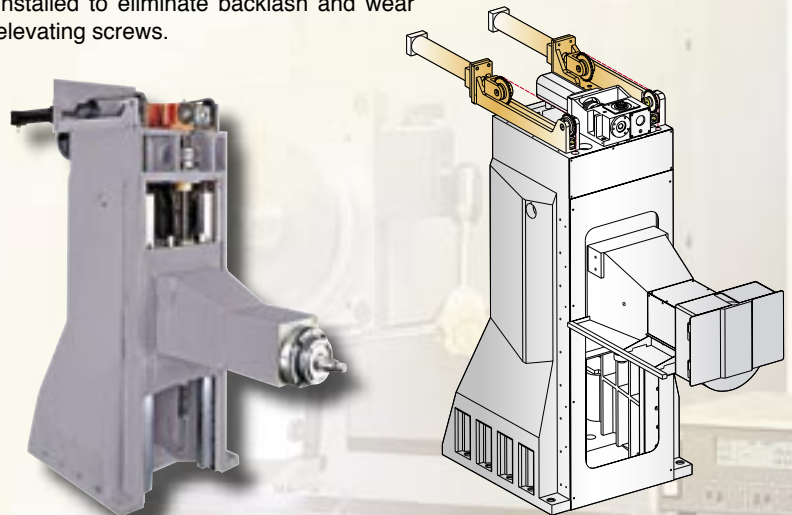

### Automatic Lubrication System

(20 & 24 series)

Equipped with a central continuous lubrication system. A warning light will illuminate if oil pressure drops below reset pressure.

- Elevating leadscrew
- Column guideways
- Cross guideways
- Table guideways
- Flow divider
- Lubricator

Note: Items marked with • are recommended to be factory installed



**MACHINE LAMP**  
B01-0903  
(12V, 50W)



**DIAMOND DRESSER**  
B03-0401  
(1.0 Carat)

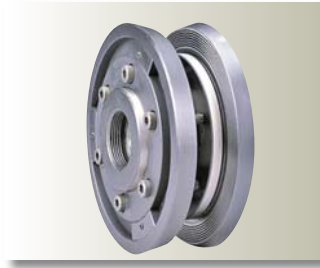

**WHEEL FLANGE**  
B05-0401  
Suitable for 14"x5"x2" (55x127x50mm)  
grinding wheel Clamping width:  
7/8"-1 1/2" (22-38mm)

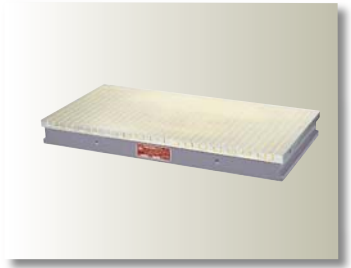

**ELECTROMAGNETIC CHUCK**  
B09-1001 (2040)  
19 5/8"x39 3/8" (500x1000mm)  
B09-1004 (2060)  
19 5/8"x29 1/2" x2pcs (500x750mm x 2pcs)  
(Voltage: 110VDC)  
\* To order B23-0705 chuck control is required.

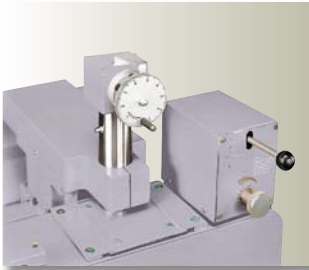

**PARALLEL DRESSING ATTACHMENT (HYDRAULIC TYPE)**  
• B13-1001  
Max. OD: 14" (355mm)  
Mini OD: 9.3" (235mm)  
Max. Length: 2.4" (60mm)



**OVERWHEEL PARALLEL DRESSER WITH AUTOMATIC DRESS COMPENSATION**  
• B13-1002  
Max. OD: 14" (355mm)  
Mini OD: 9.3" (235mm)  
Max. Length: 2.4" (60mm)



**WHEELHEAD MOUNTED AUTOMATIC ROTARY DIAMOND DRESSER WITH AUTO WHEEL DRESSING COMPENSATION**  
• B13-1003  
1750rpm (60Hz), 1450rpm (50Hz)  
1/2HP  
Max. OD: 14" (355mm)  
Mini OD: 9.3" (235mm)  
Max. Length: 2.4" (60mm)  
\*Diamond roller is not included.

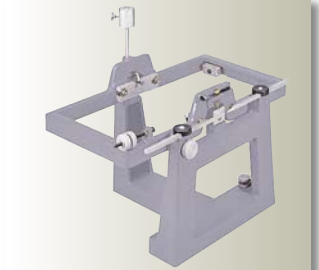

**BALANCING STAND WITH LEVELLING BUBBLE**  
B15-0301  
Max. Dia: 14" (355mm)  
Max. Width: 2" (50mm)  
**BALANCING STAND (ROLLER TYPE)**  
B15-0701  
Max. Dia: 20" (508mm)



**COOLANT SYSTEM WITH AUTO PAPER FEEDING DEVICE (With 1 Roll of Paper)**  
B17-0301  
Volume: 120L  
Paper feeding motor: 25W  
Pump: 1/8HP  
Coolant Capacity: 20L/min  
Space: 57"x24 3/8" (1450x620mm)  
Height: 30"(760mm)



**COOLANT SYSTEM WITH AUTO PAPER FEEDING DEVICE & MAGNETIC SEPARATOR (With 1 Roll of Paper)**  
B17-0302  
Volume: 120L  
Paper feeding motor: 25W  
Pump: 1/8HP  
Coolant Capacity: 20L/min  
Space: 57" x24 3/8" (1450x620mm)  
Height: 30" (760mm)



**WATER BAFFLE**  
• B19-1001 (2040)  
• B19-1002 (2060)



**CHUCK CONTROLLER**  
• B23-0705  
Input Voltage: 135VAC  
Output Voltage: 110VDC 10A  
\*With variable holding power, auto demagnetization  
\*Must be ordered with electro-magnetic chuck



**SPINDLE MOTOR**  
 • B31-1001  
 (10HP, 4P) (2040)  
 • B31-1003  
 7.5HP, 6P for 20" (508mm) wheel

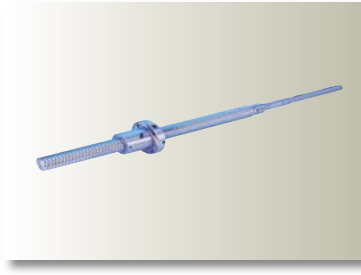

**CROSSFEED BALLSCREW**  
 • B37-1001 (metric)  
 • B37-1002 (inch)



**HYDRAULIC TEMPERATURE REGULATOR**  
 • B42-1001  
 Cooling capacity: 1000 kcal/hr



**FREQUENCY CONVERTER**  
 • B48-1001  
 (7.5HP) (Voltage: 200V-230V) (2040)  
 • B48-1002  
 (7.5HP+Transformer) (Voltage: 480V-575V, 240V, 346V) (2040)  
 • B48-1003  
 (10HP) (Voltage: 200V-230V) (2060)  
 • B48-1004  
 (10HP+Transformer) (Voltage: 480V-575V, 240V, 346V) (2060)  
 • B48-1005  
 (7.5HP) (Voltage: 380V-415V, 440V, 460V) (2040)  
 • B48-1006  
 (10HP) (Voltage: 380V, 415V, 440V, 460V) (2060)

**OPT. ACCESSORIES(24 series)**

Note: Items marked with • are recommended to be factory installed



**MACHINE LAMP**  
 B01-0701  
 (24V, 50W)

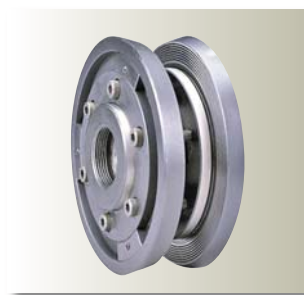

**WHEEL FLANGE**  
 B05-0701  
 Bore size: Ø5" (127mm)  
 Clamping width: 1.7"~2" (43-50mm)

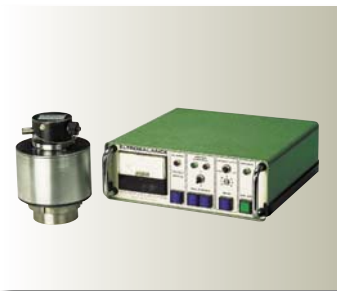

**GRINDING WHEEL DYNAMIC BALANCER**  
 • B44-0701



**HYDRAULIC TEMPERATURE REGULATOR for SPINDLE**  
 • B42-0801  
 Volume: 50L



**DIAMOND DRESSER**  
 B03-0701  
 (1.0 Carat)



**ROLLER BALANCING STAND**  
 B15-0701  
 Max. Wheel Dia: 20" (508mm)



**SPINDLE MOTOR**  
 • B31-0701  
 25HP/4p, 1700rpm/60cy,  
 1400rpm/50cy  
 • B31-0705  
 15HP/6p, 1200rpm/60cy,  
 1000rpm/50cy for ø20"  
 (ø508mm) wheel  
 • B31-0706  
 25HP/6p, 1200rpm/60cy,  
 1000rpm/50cy for ø20"  
 (ø508mm) wheel



**FREQUENCY CONVERTER**  
 • B48-0705  
 (25HP) (Voltage: 380V-460V)  
 • B48-0707  
 (25HP) (Voltage: 200V-230V)  
 • B48-0709  
 (25HP) (Voltage: 240V, 346V, 480V, 575V)  
 • B48-0710  
 (15HP) (Voltage: 200-230V)  
 • B48-0711  
 (15HP) (Voltage: 240V, 346V, 480V, 575V)  
 • B48-0712  
 (15HP) (Voltage: 380V-460V)

Note: Items marked with "●" are recommended to be factory installed

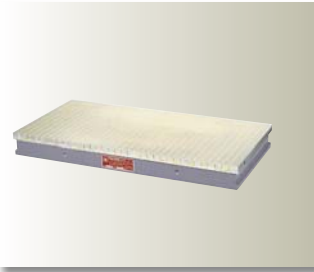

**ELECTROMAGNETIC CHUCK**  
**B09-07011**

24"x39 3/8" x 1pc  
(600x1000mm x 1pc)

**B09-0703**

24"x29 1/2"x2pcs(600x750mm)  
(Voltage: 110VDC)

**B09-0704**

24"x39 3/8" x 2pc  
(600x1000mm x 2pc)

\* To order B23-0705 chuck control is required.

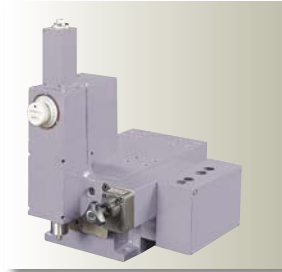

**AUTO OVER-THE-WHEEL DRESSER with AUTO DRESSING COMPENSATION**  
**● B13-0708**

Suitable for 16" (406mm) grinding wheel Max.  
OD: 16" (406mm)  
Mini OD: 9.3" (236mm)  
Max. Length: 3" (76mm)



**COOLANT SYSTEM WITH AUTO PAPER FEEDING DEVICE**  
**B17-0701**

Volume: 250L  
Pump: 1/2HP  
Coolant Capacity: 80L/min  
Space: 63"x43" (1600x1100mm)  
Height: 29 1/2"(750mm)

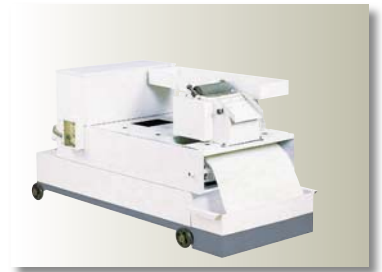

**COOLANT SYSTEM WITH AUTO PAPER FEEDING DEVICE & MAGNETIC SEPARATOR**  
**B17-0702**

Volume: 250L  
Pump: 1/2HP  
Coolant Capacity: 20L/min  
Space: 63"x43" (1600x1100mm)  
Height: 29 1/2"(750mm)



**CHUCK CONTROLLER**

**● B23-0705**

Input Voltage: 135VAC Output Voltage: 110VDC 10A, with variable holding power, auto demagnetization

\* Must be ordered with electro-magnetic chuck

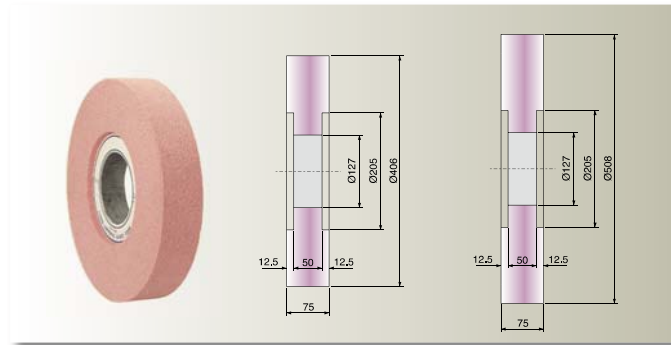

**GRINDING WHEEL**

**5122-10411630**  
Ø16"x3"xØ5"  
(Ø406x75xØ127mm)  
Double recessed

**5122-10412030**

Ø20"x3"xØ5"  
(Ø508x75xØ127mm)  
Double recessed

## STANDARD ACCESSORIES

Note: The items marked "●" with are stored in the tool box.



1. Tool box
2. Wheel flange
3. Grinding wheel
- 4. Locking nut
- 5. Wheel flange extractor
- 6. Balancing arbor
7. Hook spanners
8. Wrench
- 9. Fuse
- 10. Touch-up paint
11. Levelling pads
12. Levelling screws & nuts
13. Splash guard
14. Hydraulic temperature regulator (for 24 series)
15. Water baffle (for 24 series)

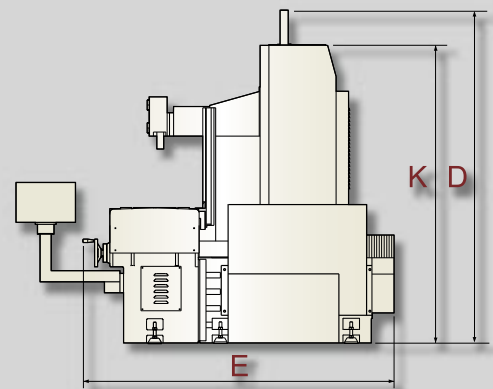
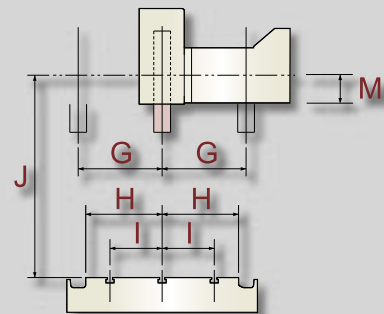
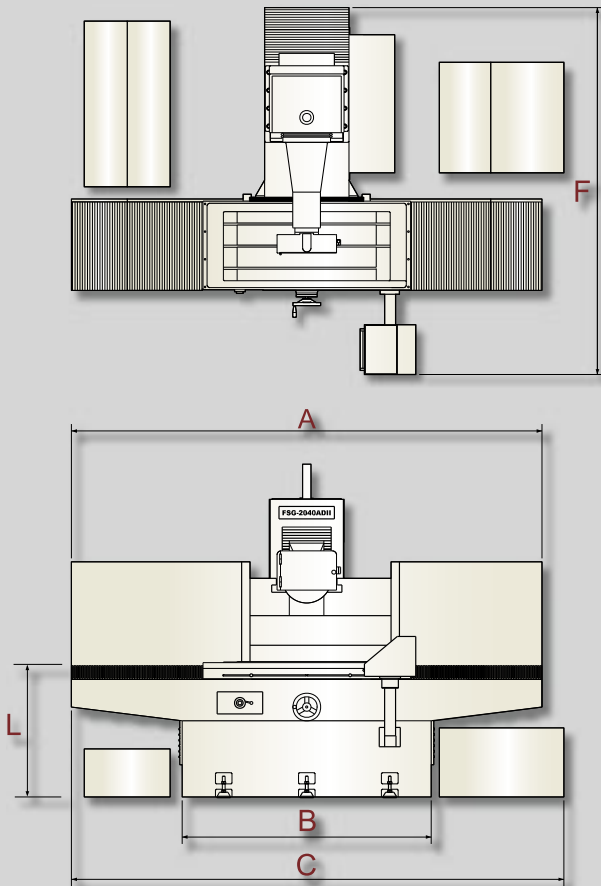

Description	2040ADII	2060ADII	2440ADII	2460ADII	2480ADII
A	133 7/8" (3400mm)	181 1/8" (4600mm)	137 3/4" (3500mm)	177 1/4" (4500mm)	236 1/4" (6000mm)
B	70 7/8" (1800mm)	110 1/4" (2800mm)	82 3/4" (2100mm)	122" (3100mm)	161 3/8" (4100mm)
C	150" (3810mm)	195" (4953mm)	152 3/8" (3870mm)	191 3/4" (4870mm)	241" (6120mm)
D	107" (2719mm)		109 3/8" (2780mm)		
E	85 5/8" (2250mm)		112 3/8" (2855mm)		
F	110 5/8" (2810mm)		144 1/8" (3660mm)		
G	11" (280mm)		11 3/5" (295mm)		
H	9 7/8" (250mm)		12" (305mm)		
I	6 5/16" (160mm)		8 1/4" (210mm)		
J	28 3/4" (730mm)		Max. 33 1/2" (850mm), Min. 6 3/4" (170mm)		
K	91" (2310mm)		N/A		
L	39" (990mm)		34 11/16" (880mm)		
M	3 3/4" (95mm)		4 5/16" (110mm)		

Notice: The manufacturer reserves the right to modify the design, specifications, mechanisms....etc. of the machine without notice. All the specifications shown above are just for reference.

# GENERAL SPECIFICATION

Description		FSG-2040ADII	FSG-2060ADII	FSG-2440ADII	FSG-2460ADII	FSG-2480DII
<b>Table Size</b>		19 5/8"x393/8" (500x1000mm)	19 5/8"x59" (500x1500mm)	24"x39 3/8" (610x1000mm)	24"x59" (610x1500mm)	24"x78 3/4" (610x2000mm)
Max. Grinding Length	Longitudinal	40"(1000mm)	60"(1500mm)	40"(1000mm)	60"(1500mm)	80"(2000mm)
Max. Grinding width	Crosswise	19 5/8"(500mm)		24"(600mm)		
Max. Travel	X Axis	43 1/4"(1100mm)	63"(1600mm)	43 1/4 "(1100mm)	63"(1600mm)	82 5/8"(2100mm)
	Z Axis	22"(560mm)		27 1/5"(690mm)		
Max. Distance from Table Surface to Spindle Centerline		28 5/8"(730mm)		33 9/16"(850mm)		
Dimension of T-slot x Quantity Table		0.551"(14mm)x3				16-82fpm(5-25m/min)
<b>Cross Transverse Travel</b>	Auto Transverse Increment	1/8"-11/4"(3-32mm)				
	Rapid Travel approx. Per Revolution	60Hz/4.9fpm(1.5m/min), 50Hz/4.08fpm(1.25m/min)				
	Per Graduation	0.2"(5mm)				
	Power Rating	0.001"(0.02mm)				1/2HP
<b>Wheelhead vertical infeed</b>	Rapid Travel approx.	15.7"/min(400mm/min)				
	MPG Least Increment	0.0001"(0.001mm)				
<b>Grinding Spindle Drive</b>	Speed	60Hz/1740r.p.m., 50Hz/1450r. p. m.				
	Power Rating	7.5HP/4P,10HP/4P(Opt.)	10HP/4P	15HP/4P(11KW), (Opt.:15HP/6P,25HP/6P,25HP/4P)		
<b>Standard Grinding Wheel</b>	Diameter	Ø14"(355mm), Ø20"(508mm)(Opt.)		Ø16"(406mm),Ø20"(508mm)(Opt.)		
	Width	2"(50.8mm)		3"(75mm)		
	Bore	Ø5"(127mm)		Ø5"(127mm)		
<b>Hydraulic</b>	Hydraulic Pump Motor	3HP	5HP	5HP/6P	7.5HP/6P	7.5HP/6P
	Tank Capacity	200L			250L	
<b>Floor Space</b>	Total Space Required	.150"118"110" (3810x2997x2794mm)	.195"x118"x110" (4953x2997x2794mm)	.145 1/4"157 1/2"128" (3700x4000x3250mm)	.185"x157"x128" (4700x4000x3250mm)	.244"x157 1/2"x128"
<b>Weights</b>	Net Weight, approx.	13640 lbs(6200kgs)	15840 lbs(7200kgs)	18480 lbs(8400kgs)	21560 lbs(9800kgs)	23320 lbs(10600kgs)
	Gross weight approx.	15290 lbs(6950kgs)	17600 lbs(8000kgs)	24530 lbs(11150kgs)	27610 lbs(12550kgs)	29150 lbs(13250kgs)
<b>Rated power approx.</b>		18HP(13.5kw)	23HP(17kw)	28HP(20.6kw)	30HP(22kw)	32HP(23.6kw)
<b>Packing dimensions (LxWxH)</b>		143.5"x90"x100" (3640x2280x2540mm)	191"x90"x100" (4850x2280x2540mm)	161"x117"x126" (4090x2970x3200mm)	194.5"x120"x126" (4940x3050x3200mm)	249"x119"x126" (6320x3020x3200mm)

Notice: □

All the specifications shown above are just for reference.

## PERMISSIBLE LOAD OF MACHINE

The total suggested maximum loads of working table are shown as follows

A = Workpiece B = Magnetic chuck C = A + B

MODEL	2040ADII	2060ADII	2440ADII	2460ADII	2480ADII
<b>A lbs</b>	1980	2420	2464	2904	2782
(kg)	(900)	(1100)	(1120)	(1320)	(1240)
<b>B lbs</b>	524	968	836	1056	1672
(kg)	(270)	(440)	(380)	(480)	(760)
<b>C lbs</b>	2574	3388	3300	3960	4400
(kg)	(1170)	(1540)	(1500)	(1800)	(2000)

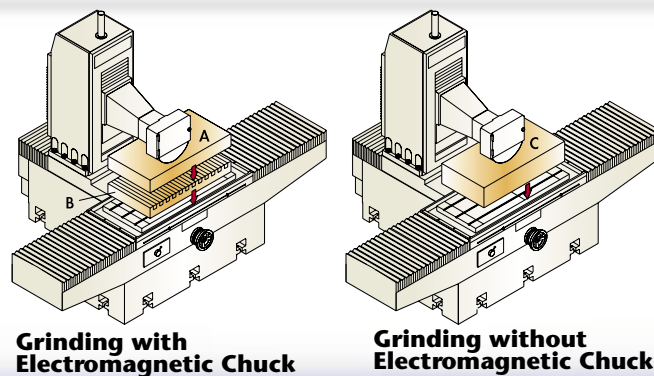

**FALCON** MACHINE TOOLS CO., LTD.

No. 34, Hsing kong Road, Shang Kang, Chang Hua TAIWAN 509

TEL: 886-4-7991126

FAX: 886-4-7980011

http://www.chevalier.com.tw

E-mail: overseas@chevalier.com.tw

TA-YA Factory TEL:886-4-25673266

U.S.A. OFFICE

**CHEVALIER** MACHINERY INC.

9925 Tabor Place Santa Fe Springs, CA 90670 U.S.A

TEL:(562)903-1929

FAX:(562)903-3959